

FOLDER-GLUERS

# COLT

AUTOMATIC BOX PACKER



HIGH RESPONSIVE  
CARTON CONVERTING  
MACHINERY



# Boosting productivity solution

## BUNDLING & STRAPPING

Introducing the Colt, a fully automatic bundling and strapping machine designed for medium to large packaging needs. It handles a wide variety of box types, from straight line and crash-lock bottom to 4- and 6-corner, accommodating materials like cardboard, micro-flute, and corrugated up to 5 layers.

With advanced features such as counting, 180° turning, stacking, strapping, and bundling, the Colt integrates seamlessly with all folder gluers on the market, boosting productivity and reducing labor costs in one streamlined pass.

## AT A GLANCE

 **FAST PROCESSING**

 **WIDE RANGE**

 **MATERIALS**  
Cardborad  
Micro-flute  
Corrugated

 **FLEXIBLE &  
EASY TO OPERATE**

  **CERTIFICATED**

## BOXES

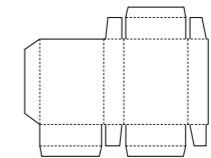

Straight line

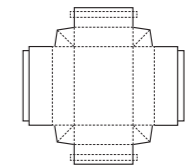

Double - wall

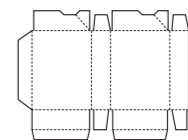

Lock - bottom

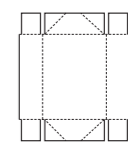

4 - corner

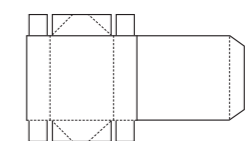

4 - corner  
with Lid

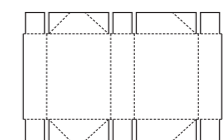

6 - corner

# COLT

AUTOMATIC BOX PACKER



1  
Delivery section

The Delivery Section smoothly transports the finished package, making it easy to collect and prepare for delivery.



2  
Bundling & strapping section

Final bundling & strapping of the box batch, creating a tight, square package that is easy to handle, deliver, and palletize.



3  
Stacking section

Ensures that boxes oriented in both directions are aligned and squared perfectly.



5  
180 ° turn section

Rotates every other group of boxes 180°, ensuring that the batch is evenly squared and properly oriented.



6  
Counting & separating section

Accurately counts boxes and separates them into groups of specific units, ensuring precise organization for the next step.

## SPECIFICATIONS

### COLT

#### Processed materials

Carton board max.	1200 g/m <sup>2</sup>
Corrugated flute type	B, C, N, E, F, AB, 3 & 5 layers

#### Capability

Speed max.	9 s/bundle (full configuration) 4.5 s/bundle (counting & separation, stacking)
Bundle height	80 - 300 mm
Folded box width	235 - 800 mm
Folded box length	230 - 800 mm
Distance between strap edge to box edge	Min. 80 mm
Distance between straps	Min. 170 mm
Bundle	Min. W100 x L120 x H30 mm Max. W400 x L430 x H140 mm
Strap type	PP, PE

#### Dimensions & weight

Length	7.6 m (full configuration) 4.3 m (counting & separation, stacking)
Width	1.9 m
Height	2.13 m (full configuration) 1.8 m (counting & separation, stacking)
Weight	9000 kg (full configuration) 3500 kg (counting & separation, stacking)

#### Installation

Power supply	25 kw (full configuration) 10 kw (counting & separation, stacking)
Compressed air	6 bar
Air compressor capacity	30 m <sup>3</sup> /h
Air tank capacity	155 L



### SCHEME COLT

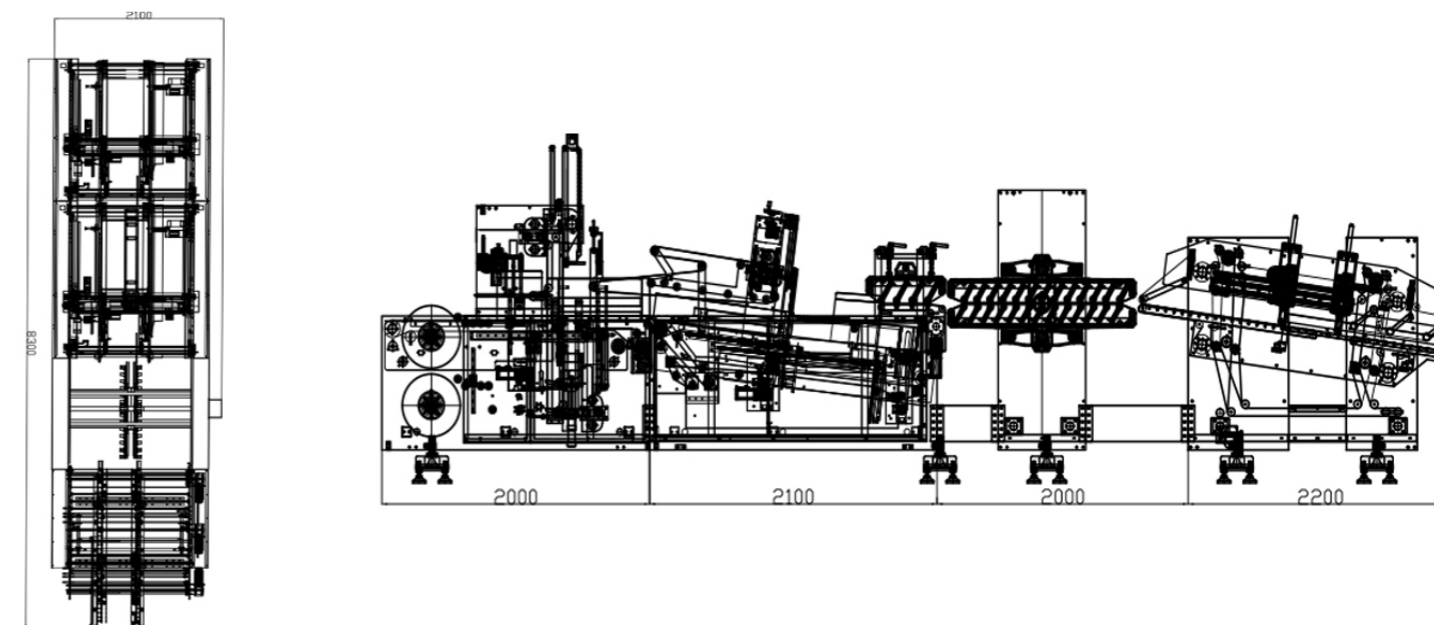



[info@dgm-global.com](mailto:info@dgm-global.com)  
[www.dgm-global.com](http://www.dgm-global.com)

TEL (86) 0752-277 37 80  
FAX (86) 0752-277 37 78

HuiHuan Industrial Area, Huizhou City,  
Guangdong Province, China

DGM Technology (China) Co., Ltd